

Krantz

Step twist outlets DS....

Air distribution systems

Krantz

Step twist outlets

Preliminary remarks

Step twist outlets are used for air supply to assembly rooms with banked seating, e.g. lecture halls, conference halls, cinemas, theatres, etc. The outlets are installed in step fronts.

In the floor zone step twist outlets generate turbulent mixing air flow, which has the advantage of rapid temperature equalization between supply air and indoor air. At about 0.5 m above the floor the air flows upwards – similar to displacement ventilation – displacing the warm, stale indoor air to the return air collectors in the ceiling zone.

Construction design and placement

The outlet elements used are tried and tested outlets **1** from Krantz:

- Twist outlets with circular exit, DN 63 and DN 100.
- Radial outlets with circular face DN 100.
- Adjustable floor outlets DN 150 set for displacement flow.

Step twist outlets are suitable for installation in wooden steps (or similar material) or concrete steps (Figure 2).

For installation in wooden steps a cylindrical sheet hood **2** is supplied to ensure even supply air distribution. On the intake side it is fitted with a perforated sheet metal disc which acts as a fixed damper **3**.

For fastening in the wooden step the hood is fitted with two opposite clips **6** which are flexed against the inside of the step front **5** when the sheet hood is inserted from the room. The sheet hood is then fastened with tacks or screws **7** in the circular step cutout **4**. Then the outlet can be inserted from the room and screwed to the fixed damper **3** with a threaded bolt **8** and a rivet nut **9**.

For outlet placement in concrete steps it is better to use bores **10** in the step front instead of sheet hoods. A perforated metal sheet acting as a fixed damper **3** is fitted to the inside of the step at the client's expense or premounted when constructing the concrete casing. A shell pipe with built-in fixed damper is also available on request.

The outlet in this case is fastened with a threaded bolt **8** and a rivet nut **9** in the centre of the fixed damper.

To avoid any damage to the outlets and the sheet hoods it is best to install them at the end of the construction phase.

While the outlet types twist outlet DS-DD and radial outlet DS-RA cover the front side of the step cutout or bore with their exit flanges **11**, the floor outlet DS-BA covers it with the clamp ring with clip-on flange **13**.

For smooth installation and function of the step twist outlets the minimum necessary clear step height is h_{min} (Figure 1). For lower steps the exit flange diameter for DS-DD can be minimized to fit a lower clear step height h^* .

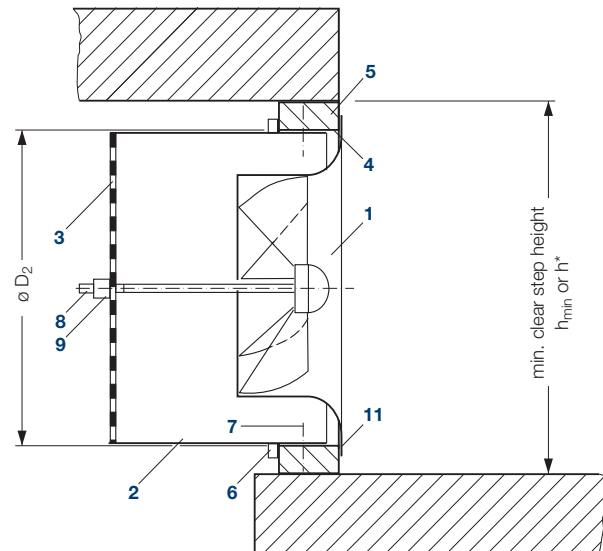

Fig. 1: Mounting detail, shown here for twist outlet DS-DD in a wooden step

Selection and layout specifications

Step twist outlets				
Type	DS-DD		DS-RA	DS-BA
Nominal diameter	DN 63	DN 100	DN 100	DN 150
max. volume flow rate	l/s	3.5	10	10
	m ³ /h	12	35	35
Number per seat	units	3	1	1
Minimum centre spacing	mm	150	500	500
Maximum sound power level	dB(A) ref. 10 ⁻¹² W	12	16	18
Maximum pressure drop	Pa	22	20	20

Step twist outlets

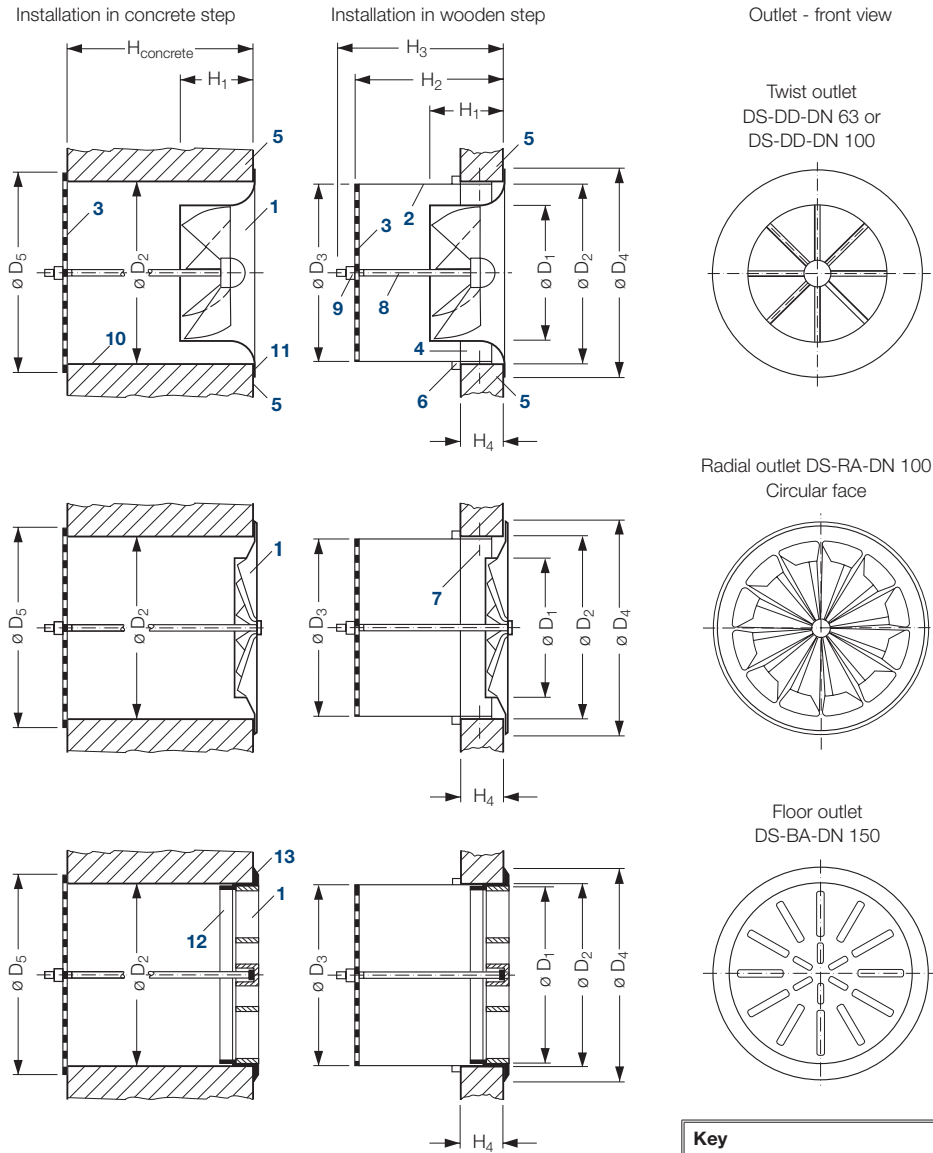

Fig. 2: Installation in wooden and concrete steps

		DS-DD		DS-RA	DS-BA	
		DN 63	DN 100	DN 100	DN 150	
Bore \varnothing	D_1	mm	62	99	99	150
	D_2	mm	80	125	125	165
	D_3	mm	79	124	124	163
External \varnothing	D_4	mm	110	165	150	172
External \varnothing	$D_4^* 1)$	mm	85	130	—	—
	D_5	mm	140	185	185	220
	h_{min}	mm	95	145	138	169
	$h^* 1)$	mm	83	128	—	—
	H_1	mm	30	42	24	46
	H_2	mm	100	100	100	100
	H_3	mm	113	116	118	119
	$H_4 2)$	mm	18 – 85	18 – 85	18 – 85	18 – 85
	$H_{concrete}$	mm	≥ 100	≥ 100	≥ 100	≥ 100

Key	Material
1 Outlet	
– Twist outlet	plastic
– Radial outlet	painted sheet metal
– Floor outlet with clamp ring	plastic
2 Sheet hood	aluminium
3 Fixed damper	galvanized sheet metal
4 Step cutout	wood or similar material
5 Step front	—
6 Clip	aluminium
7 Tack or screw	
8 Threaded bolt ³⁾	galvanized steel
9 Rivet nut ³⁾	
10 Bore	—
11 Exit flange	plastic or sheet metal
12 Clamp ring	
13 Clip-on flange	plastic

1) Minimum flange $\varnothing D_4^*$ for step height $h^* < h_{min}$

2) Possible thickness of wooden step front; specify exact dimension when ordering

3) M6 for DS-DD and DS-RA, use M8 for DS-BA

Step twist outlets

Mode of operation

The supply air flows from the floor plenum into the step twist outlets. The perforated metal sheet in the outlet intake generates a slightly higher pressure resulting in even air distribution.

The radial discharge flow is turbulent and twisted, which causes an intensive mixing of the supply air and ambient air on immediate discharge from the outlet in the floor zone. This results in smaller temperature stratification in the occupied zone than with pure displacement ventilation. For these reasons the minimum supply air temperature can amount to 18 °C. In the floor zone the air temperatures are ≥ 21 °C and in the head zone of seated persons 22.5 – 23 °C. The vertical temperature gradient in the occupied zone is ≤ 1.5 K/m (Figure 3).

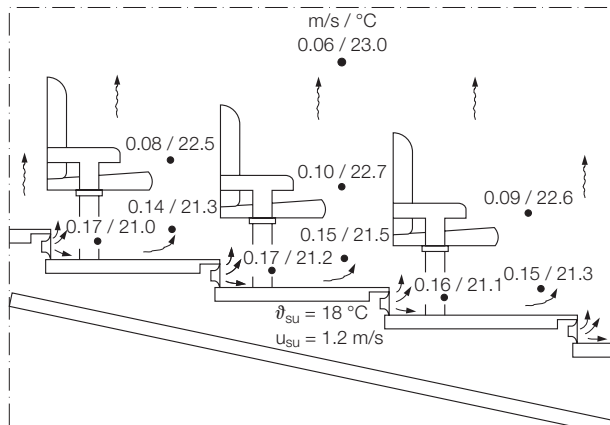

Fig. 3: Example of air velocities and temperatures. The supply air volume flow rate amounts to 10 l/s [35 m³/h] per seat; the temperature difference between supply air and indoor air is -5 K.

Due to the intensive induction of the indoor air in the floor zone, the jet velocity drops so rapidly that at audience level the air velocity amounts to max. 0.15 m/s at a turbulence intensity of 40 – 45%.

At a height of 0.5 m above the floor the supply air disperses in the form of displacement ventilation, i.e. when it encounters heat sources (people, notebooks, etc.) the fresh air ascends and displaces the warm, stale indoor air to the return air collectors at the ceiling. At ≥ 0.5 m above the floor the indoor air velocities are ≤ 0.10 m/s.

The flow pattern formed (fresh air ascends when it encounters heat sources and displaces pollutants and heat into the ceiling zone) raises the air quality in the occupied zone.

Due to the heat removal upwards the return air temperature exceeds the room temperature in the seating zone. That is why despite the relatively low temperature difference of 4 – 5 K between the indoor air in the head zone of the audience and the supply air, the heat loads of people and lighting can be effectively removed. Depending on room height and heat load to be removed, the maximum temperature difference between supply air and return air can amount to -12 K.

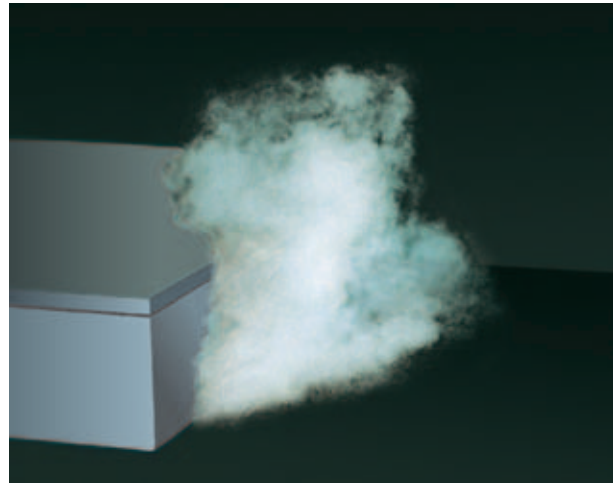

Fig. 4: Step twist outlet, spread of supply air jets



Fig. 5: Step twist outlets DD-DD-DN 100 in a lecture hall

Step twist outlets

Sound power level and pressure drop

The sound power level of the step twist outlets is low. It meets the high acoustic requirements for theatres and similar assembly rooms. Sound power level and pressure drop for all step twist outlets are shown in Figure 6.

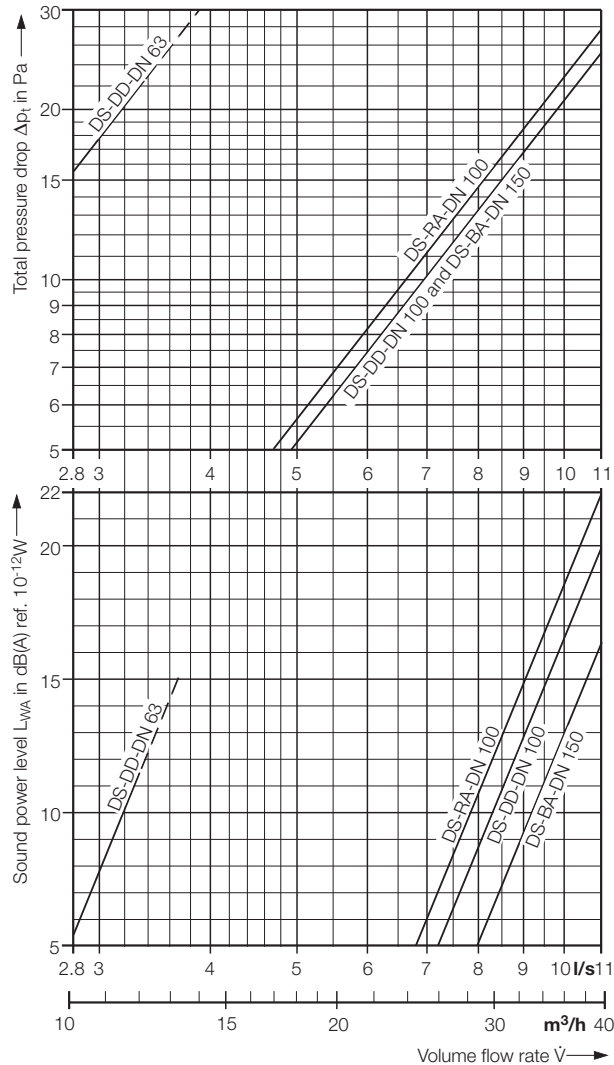

Fig. 6: Sound power level and pressure drop

Type ¹⁾	Air outlet volume flow rate		Pressure drop Pa	L_{WA} dB(A)	Sound power level L_W in dB ref. 10^{-12}W ²⁾					
	l/s	m^3/h			Octave band centre frequency in Hz					
					125	250	500	1 000	2 000	4 000
DS-BA-DN 150	8	30	14.5	6.5	—	—	—	—	—	—
	10	35	20	12	13	15	11	—	—	—
	11	40	28	18	18	21	17	14	10	—
DS-DD-DN 100	8	30	14.5	10.5	10	14	—	—	—	—
	10	35	20	15.5	15	19	13	10	—	—
	11	40	28	19.5	19	23	17	14	—	—
DS-RA-DN 100	8	30	16	12.5	11	15	10	—	—	—
	10	35	22	17.5	16	20	15	14	—	—
	11	40	30	21.5	20	24	19	18	12	—

¹⁾ Values for DS-DD-DN 63 on request

²⁾ Values < 10 dB not shown

Features

- Air distribution system for lecture halls, conference halls, theatres and other assembly rooms with fixed or removable seating on stepped floors
- Outlets built into step front
- Intensive mixing of supply air jets with indoor air in the floor zone resulting in low vertical temperature stratification in the occupied zone
- Supply air flow in the form of displacement upflow from the floor zone
- Draught-free air supply in the occupied zone
- Discharge element available in three designs
- Low sound power level
- Maximum air outlet volume flow rate 3.5 or 10 l/s [12 or 35 m^3/h] depending on type
- Temperature difference between supply air and indoor air up to -5 K and between supply air and return air up to -12 K , depending on room heat load and height
- Also usable in very low step fronts (minimum step height for DS-DD-DN 63 = 84 mm)
- Air outlet can be installed from the room
- Low outlay option for comfortable climate
- Ideal when renovating theatres and other assembly rooms
- Available for step front thickness from 18 to 85 mm and concrete steps from 100 mm upwards

Step twist outlets

Type code

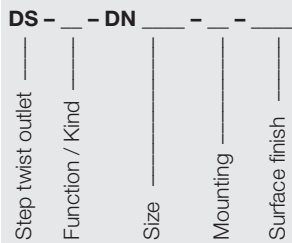

Function / Kind

- DD = twist outlet
- RA = radial outlet ¹⁾
- BA = floor outlet

Size

	DS-DD	DS-RA	DS-BA
63 = DN 63	•		
100 = DN 100	•	•	
150 = DN 150			•

Mounting

- C = installation in a concrete step
- W = installation in a wooden step

Surface finish

- 7038 = RAL 7038, agate grey (twist outlet) ³⁾
- 7037 = RAL 7037, dusty grey (floor outlet) ³⁾
- = face painted to RAL (radial outlet)

Tender text

..... units

Step twist outlet for installation in a step front, to generate twisted supply air jets for direct draught-free fresh air supply to the occupied zone with rapid temperature equalization between supply air and indoor air in the floor zone,

consisting of:

- twist outlet, radial outlet with circular face, or floor outlet with clamp ring;
- sheet hood for outlet installation in the cutout of a **wooden step** ²⁾ (or similar material) made at client's expense, including built-in fixed damper for even air supply to all air outlets connected to a plenum;
- fixed damper for even air supply to all air outlets connected to a plenum; fixed damper installed on the intake side in front of the bore in the **concrete step** made at client's expense.

Screw connection for fastening air outlet to step front from the room.

Material:

- Twist outlet made of plastic body-tinted to RAL 7038, agate grey ³⁾
- Radial outlet made of galvanized sheet metal, powder-coated to RAL
- Floor outlet with clamp ring made of plastic body-tinted to RAL 7037, dusty grey ³⁾
- Sheet hood made of aluminium
- Fixed damper made of galvanized sheet metal

Make:

Krantz

Type:

DS - - - DN - - -

Subject to technical alterations.

¹⁾ Square face on request

²⁾ Specify thickness of steps made of wood or similar material

³⁾ Other colour on request

Krantz GmbH

Uersfeld 24, 52072 Aachen, Germany

Phone: +49 241 441-1

Fax: +49 241 441-555

info@krantz.de | www.krantz.de

The logo for Krantz GmbH, featuring the word "Krantz" in a stylized, blue, cursive script font.